



SANDPIPER® 

# SERIES



## **EPC DATA SUBMITTAL PACK**

Customizable Pump Data Sheet for RFQ (with limited scope of supply)  
Specifications and Performance Data Sheet

|                  |  |   |             |   |          |  |                                  |               |
|------------------|--|---|-------------|---|----------|--|----------------------------------|---------------|
| Requester's LOGO | NATURAL GAS OPERATED DOUBLE DIAPHRAGM<br><br>PUMP DATA SHEET   |   |             |   |          | Document No. _____<br><br>Revision No. _____<br><br>Item No. _____ | C<br>h<br>a<br>n<br>g<br>e<br>s  |               |
| For:             | Proposal   | <input type="checkbox"/>  | Purchase    | <input type="checkbox"/>                                      | As Built | <input type="checkbox"/>   |                                  |               |
| 1                | Contract No.   |   |             |   |          |  |                                  |               |
| 2                | Purch Order  |   |             |   |          |  |                                  |               |
| 3                | Tag/Item No.   |   |             |   |          |  |                                  |               |
| 4                | Client Name:   |   |             |   |          |  |                                  |               |
| 5                | Location:  |   |             |   |          |  |                                  |               |
| 6                | Service Area:  | Hazardous Area Classification: Zone _____ Group _____ Class _____ |             |   | Other:   | Unclassified (non-Hazardous) <input type="checkbox"/>              |                                  |               |
| 7                | Applicable Standards:  |   |             |   |          |  |                                  |               |
| 8                | Manufacturer:  | Quantity:   |             | Pumps in Operation:   |          | Spare(s):  |                                  |               |
| 9                | Pump Size :  |   |             |   |          |  |                                  |               |
| CONSTRUCTION     |  |   |             | OPERATING CONDITIONS & LIQUID CHARACTERISTICS (for each pump) |          |  |                                  |               |
| 10               | Liquid End:  |   |             | Service / Duty (Intermittent/Continuous)                      |          |  |                                  |               |
| 11               | Gas End (Center Section):  |   |             | Fluid Pumped:   |          |  |                                  |               |
| 12               | Connections:   | Size  | ANSI Rating | Face  | Type     | Position   | Corrosion/Erosive Due To:        |               |
| 13               | Suction:   |   |             |   |          | Top  | Liquid Temperature (PT): °F / °C |               |
| 14               | Discharge:   |   |             |   |          | Bottom   | Ambient Temperature: °F / °C     |               |
| 15               | Gas Inlet:   |   |             |   |          | N/A  | Specific Gravity @Duty PT:       |               |
| 16               | Hydrotest Pressure:  | 500 psig  |             |   |          |  | Viscosity @Duty PT:              | cps           |
| 17               | No. of Diaphragm Chambers:   | 2   |             |   |          |  | Vap. Pressure @Duty PT           | psia/bara     |
| 18               | Inlet and Outlet Valve Type:   |   |             | Discharge Pressure  |          |  |                                  | psig/barg     |
| 19               | Pump Type:   |   |             | Suction Pressure  |          |  |                                  | psig/barg     |
| 20               |  |   |             | Capacity @ PT:  |          |  |                                  | gpm / m3/hr   |
| 21               |  |   |             | Gas Supply Pressure:  |          |  |                                  | psig/barg     |
| 22               |  |   |             | Gas Supply Pressure:  |          |  |                                  | psig/barg     |
| 23               |  |   |             | NPSH Available  |          |  |                                  | FT/M          |
| 24               |  |   |             | H <sub>2</sub> S Concentration                                |          |  |                                  | ppvm          |
| 25               |  |   |             | Solids  |          |  |                                  | Size / % Conc |
| MATERIALS        |  |   |             | PERFORMANCE   |          |  |                                  |               |
| 26               | Diaphragms:  |   |             | Rated Capacity (GPM/M3/Hr):                                   |          |  |                                  |               |
| 27               | Check Valve Balls/Flaps:   |   |             | NPSH Required (FT/M):   |          |  |                                  |               |
| 28               | Check Valve Seats:   |   |             | Max Gas Consumption: (scfm / m3/hr)                           |          |  |                                  |               |
| 29               | Gas Valve O'rings:   |   |             | Max Gas Inlet Pressure : (psig/barg)                          |          |  |                                  |               |
| 30               | Gas Valve Gaskets  |   |             | Max Discharge Pressure: (psig/barg)                           |          |  |                                  |               |
| 31               | Suction Manifold   |   |             | LAB TEST  |          |  |                                  |               |
| 32               | Discharge Manifold   |   |             | REQUIRED  |          |  |                                  |               |
| 33               | Inlet Gas Inlet Valve  |   |             | WITNESSED   |          |  |                                  |               |
| 34               | Inlet Gas Regulator (Max 100 psig)   |   |             | Hydrostatic Test:   |          |  |                                  |               |
| 35               | Inlet Gas Filter   |   |             | Performance Test:   |          |  |                                  |               |
| 36               |  |   |             | Snoop Test: (see line 57 below)                               |          |  |                                  |               |
| 37               |  |   |             | Other:  |          |  |                                  |               |
| 37               |  |   |             | Other:  |          |  |                                  |               |
| SCOPE OF SUPPLY  |  |   |             |   |          |  |                                  |               |
| 38               | Pump Type/Design:  |   |             |   |          |  |                                  |               |
| 39               | Compressed natural gas powered, double diaphragm pump  |   |             |   |          |  |                                  |               |
| 40               | Bolted fluid and gas housing connections   |   |             |   |          |  |                                  |               |
| 41               | NPT threaded or ANSI flanged process fluid connections   |   |             |   |          |  |                                  |               |
| 42               | Main gas valve and pilot valve to be repairable or replaceable without disconnecting process fluid connections or disassembling fluid housings                 |   |             |   |          |  |                                  |               |
| 43               | Natural gas exhaust to be a single connection  |   |             |   |          |  |                                  |               |
| 44               | Materials of Construction:   |   |             |   |          |  |                                  |               |
| 45               | Aluminum or stainless steel gas housings   |   |             |   |          |  |                                  |               |
| 46               | Aluminum or stainless steel liquid housings  |   |             |   |          |  |                                  |               |
| 47               | Nitrile or PTFE diaphragms   |   |             |   |          |  |                                  |               |
| 48               | Nitrile or PTFE check balls  |   |             |   |          |  |                                  |               |
| 49               | Nitrile or Viton gas end seals   |   |             |   |          |  |                                  |               |
| 50               | Diaphragm connecting rod to be 416 stainless steel or 316 stainless steel  |   |             |   |          |  |                                  |               |
| 51               | Certifications:  |   |             |   |          |  |                                  |               |
| 52               | CSA certified to ANSI LC6-2008 Natural Gas Operated Diaphragm Pumps (USA)  |   |             |   |          |  |                                  |               |
| 53               | CSA certified to Technical Information Letter No. R-14 Natural Gas Operated Diaphragm Pumps (Canada)   |   |             |   |          |  |                                  |               |
| 54               | Meets NACE MR0175/ISO 15156 Material Recommendations   |   |             |   |          |  |                                  |               |
| 55               | ATEX Certified: Group II, Category 2 (Aluminum gas or fluid housings); Group II, Category 1 (Stainless steel gas and fluid housings)                           |   |             |   |          |  |                                  |               |
| 56               | Manufacturing and Production Tests:  |   |             |   |          |  |                                  |               |
| 57               | 100% testing of gas-containing housings - pumps shall not leak externally at a rate in excess of 200 cm <sup>3</sup> per hour at 150 PSI test pressure         |   |             |   |          |  |                                  |               |
| 58               | All parts of the pump subjected to pressure, except the pumping diaphragms, shall withstand a hydrostatic test of 5 times the maximum rated operating pressure |   |             |   |          |  |                                  |               |
| 59               | Resistance to static electric charge; dissipation shall not exceed one mega-ohm between the grounding connection and each metal component                      |   |             |   |          |  |                                  |               |
| 60               | Temperature Limits:  |   |             |   |          |  |                                  |               |
| 61               | Minimum: -10°F (-23°C)   |   |             |   |          |  |                                  |               |
| 62               | Maximum: 180°F (82°C)  |   |             |   |          |  |                                  |               |
| REMARKS          |  |   |             |   |          |  |                                  |               |
| 63               |  |   |             |   |          |  |                                  |               |
| 64               |  |   |             |   |          |  |                                  |               |
| 65               |  |   |             |   |          |  |                                  |               |
| 66               |  |   |             |   |          |  |                                  |               |
| 67               |  |   |             |   |          |  |                                  |               |
| 68               |  |   |             |   |          |  |                                  |               |

# DATA SHEET

## Specifications & Performance

### Certified Quality



Quality System  
ISO9001 Certified



Environmental Management System  
ISO14001 Certified



Certified to CSA Technical Letter No, R-14



Certified to ANSI LC6-2008

Warren Rupp, Inc.

A Unit of IDEX Corporation

800 N. Main St.,

Mansfield, Ohio 44902 USA

Telephone 419.524.8388

Fax 419.522.7867

WWW.SANDPIPERPUMP.COM



© Copyright 2013 Warren Rupp, Inc.  
All rights reserved

# Model G20

## Metallic

### Design Level 1

#### Natural Gas-Operated Diaphragm Pumps

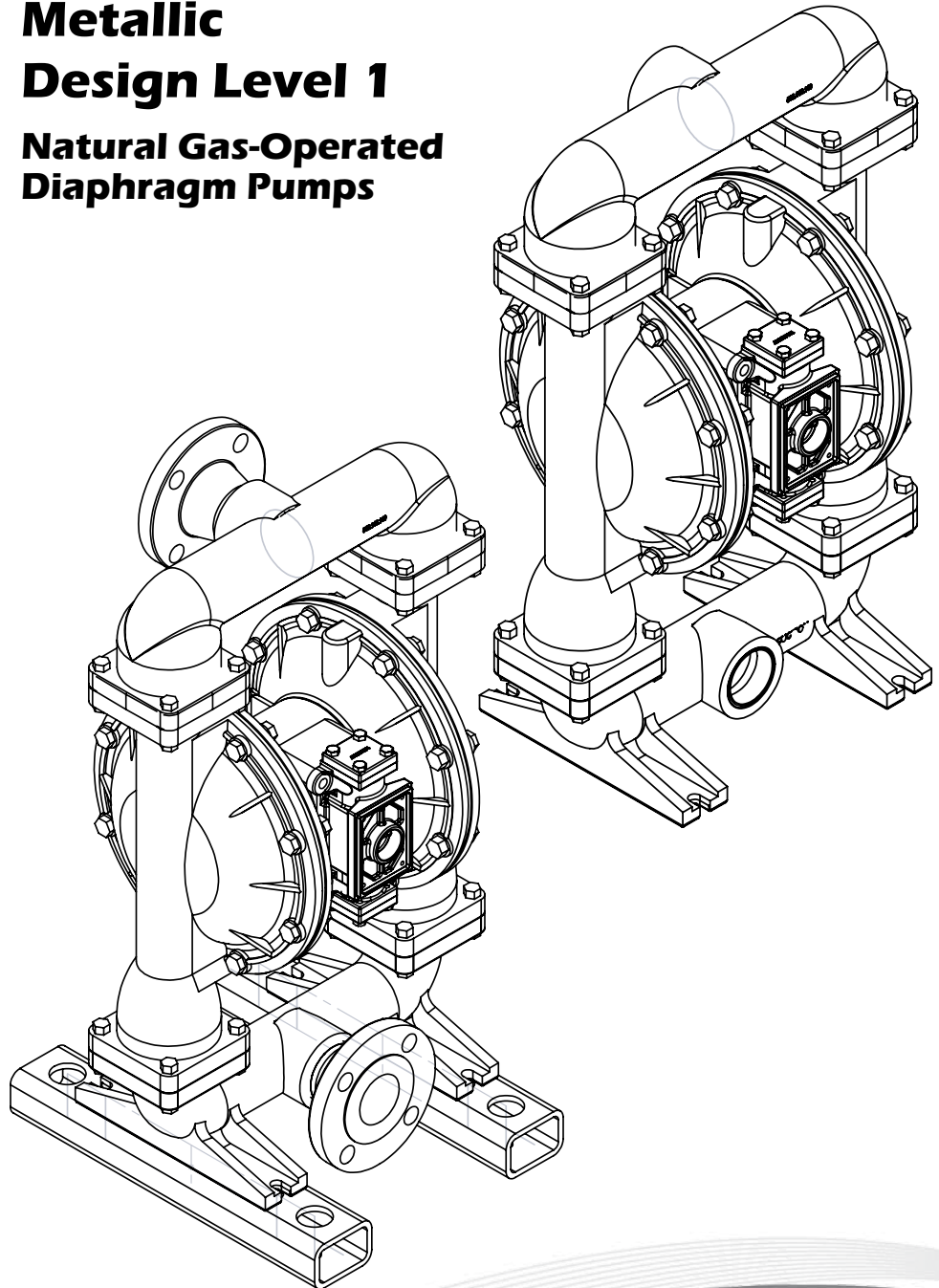

**SANDPIPER**<sup>®</sup>  
A WARREN RUPP, INC. BRAND

WWW.SANDPIPERPUMP.COM

# Explanation of Pump Nomenclature

Your Model #: **G**

(fill in from pump nameplate)

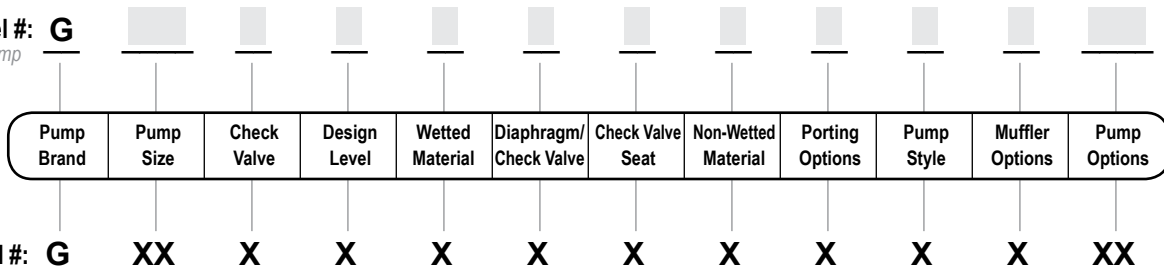

## Pump Brand

G Gas Operated

## Pump Size

20 2"

## Check Valve Type

B Ball

## Design Level

1 Design Level

## Wetted Material

S Stainless Steel

A Aluminum

## Diaphragm/Check Valve Materials

B Nitrile/Nitrile

T PTFE -Nitrile/PTFE

5 Nitrile/PTFE

## Check Valve Seat

B Nitrile

T PTFE

A Aluminum

S Stainless Steel

## Non-Wetted Material Options

A Painted Aluminum

B Unpainted Aluminum with Stainless Steel Gas Valve

D Unpainted Aluminum with Stainless Steel Gas Valve with FKM O-rings

X Unpainted Aluminum

0 Unpainted Aluminum/FKM Elastomers

V Unpainted Aluminum/FKM Elastomers

S Stainless Steel/ S02/304 SS Hardware

T Stainless Steel/ 316 Stainless Hardware

7 Painted Stainless Steel

8 Stainless Steel/FKM Elastomers

9 Painted Stainless Steel/FKM Elastomers

## Porting Options

N NPT Threads

B BSP (Tapered) Threads

R 150# Raised Face 2" ANSI Flange w/ Threaded Pipe Connections

W 150# Welded Raised Face 2" ANSI Flanged Manifolds

## Pump Style

S Standard

## Muffler Options

X No Muffler Permitted \*

Your Serial #: (fill in from pump nameplate) \_\_\_\_\_

## ATEX Detail

(1)  II 1G c T5  
II t G c T5  
II 1D c T100°C †  
I M1 c  
I M2 c  
Models equipped with Wetted Option S Non-Wetted Options S, T, 7, 8, or 9, Pump Option X.  
**Note:** See ATEX Explanation of EC-Type Certificate

(2)  II 2G c T5  
II 3/2 G c T5  
II 2D c T100°C †  
Models equipped with Wetted Options A or S, All Non-Wetted Options, Pump Option X.  
**Note:** See ATEX Explanation of Type Examination Certificate

# Performance

## G20 METALLIC

### SUCTION/DISCHARGE PORT SIZE

- 2"

### CAPACITY

- 0 to 150 gallons per minute  
(0 to 567 liters per minute)

### GAS DISTRIBUTION VALVE

- No-lube, no-stall design

### SOLIDS-HANDLING

- Up to .25 in. (6mm)

### HEADS UP TO

- 100 psi or 231 ft. of water  
(7 bar or 70 meters)

### MAXIMUM OPERATING PRESSURE

- 100 psi (7 bar)

### DISPLACEMENT/STROKE

- .42 Gallon / 1.59 liter

### SHIPPING WEIGHT

- Aluminum 69 lbs. (31kg)
- Stainless Steel 114 lbs. (52kg)

These pump models are designed to pump the following fluids:  
Crude Oil, Salt Water, Drilling Mud, Condensate, Lubrication Oils,  
Glycol, Caustic Liquids, and Acids."

### MODEL G20 Metallic Performance Curve

Performance based on the following: elastomer fitted pump, flooded suction, water at ambient conditions.  
The use of other materials and varying hydraulic conditions may result in deviations in excess of 5%.

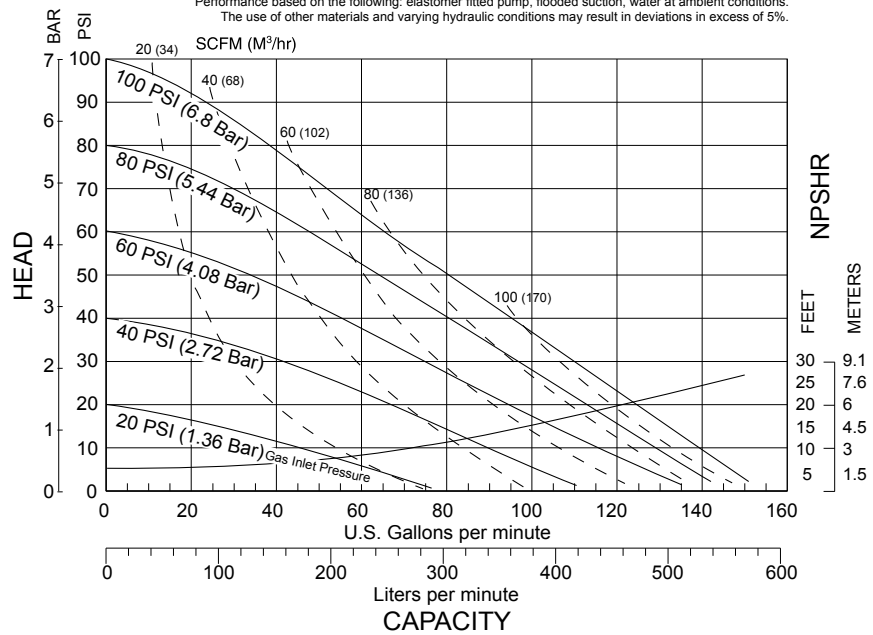

**Exhaust Gas:** The exhausted natural gas must be vented to a low pressure safe location in accordance with local fire safety and environmental codes, or in the absence of local codes, an industry or nationally recognized code having jurisdiction over the specific installations, and/or CAN/CGA B149, Installation Codes

## Materials

| Material Profile:  | Operating Temperatures: |                |
|--|-------------------------|----------------|
|  | Max.                    | Min.           |
| <b>CAUTION!</b> Operating temperature limitations are as follows:<br><b>FKM:</b> (Fluorocarbon) Shows good resistance to a wide range of oils and solvents; especially all aliphatic, aromatic and halogenated hydrocarbons, acids, animal and vegetable oils. Hot water or hot aqueous solutions (over 70°F(21°C)) will attack FKM.     | 350°F<br>177°C          | -40°F<br>-40°C |
| <b>Nitrile:</b> General purpose, oil-resistant. Shows good solvent, oil, water and hydraulic fluid resistance. Should not be used with highly polar solvents like acetone and MEK, ozone, chlorinated hydrocarbons and nitro hydrocarbons.   | 190°F<br>88°C           | -10°F<br>-23°C |
| <b>Virgin PTFE:</b> (PFA/TFE) Chemically inert, virtually impervious. Very few chemicals are known to chemically react with PTFE; molten alkali metals, turbulent liquid or gaseous fluorine and a few fluoro-chemicals such as chlorine trifluoride or oxygen difluoride which readily liberate free fluorine at elevated temperatures. | 220°F<br>104°C          | -35°F<br>-37°C |
| Maximum and Minimum Temperatures are the limits for which these materials can be operated. Temperatures coupled with pressure affect the longevity of diaphragm pump components. Maximum life should not be expected at the extreme limits of the temperature ranges.  |                         |                |
| <b>Metals:</b>   |                         |                |
| <b>Stainless Steel:</b> Equal to or exceeding ASTM specification A743 CF-8M for corrosion resistant iron chromium, iron chromium nickel and nickel based alloy castings for general applications. Commonly referred to as 316 Stainless Steel in the pump industry.  |                         |                |

For specific applications, always consult the Chemical Resistance Chart.

**Ambient temperature range:** -20°C to +40°C

**Process temperature range:** -20°C to +80°C for models rated as category 1 equipment  
-20°C to +100°C for models rated as category 2 equipment

In addition, the ambient temperature range and the process temperature range do not exceed the operating temperature range of the applied non-metallic parts as listed in the manuals of the pumps.

# Dimensional Drawings

## G20 Metallic

Dimensions in inches (mm dimensions in brackets). Dimensional Tolerance:  $\pm 1/8"$  ( $\pm 3\text{mm}$ )

The dimensions on this drawing are for reference only. A certified drawing can be requested if physical dimensions are needed.

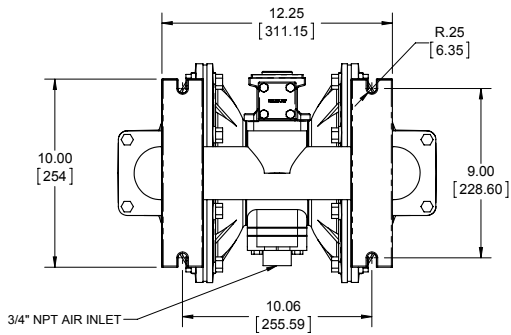
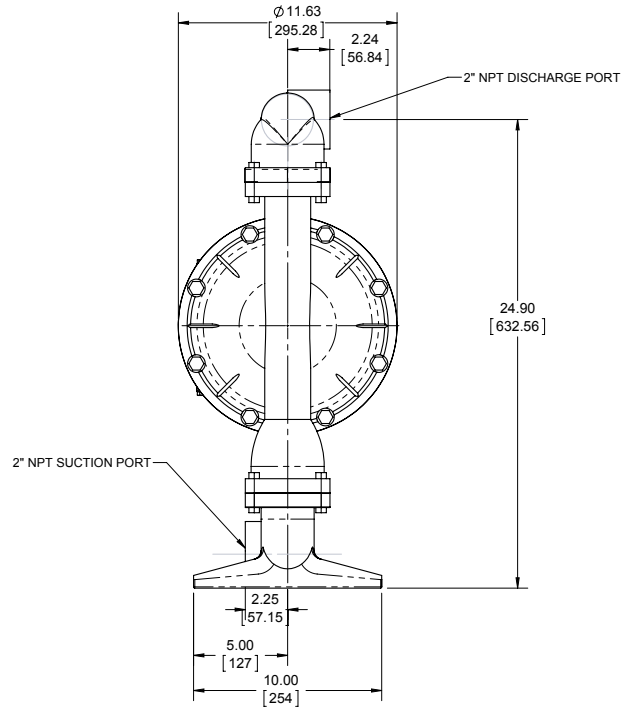
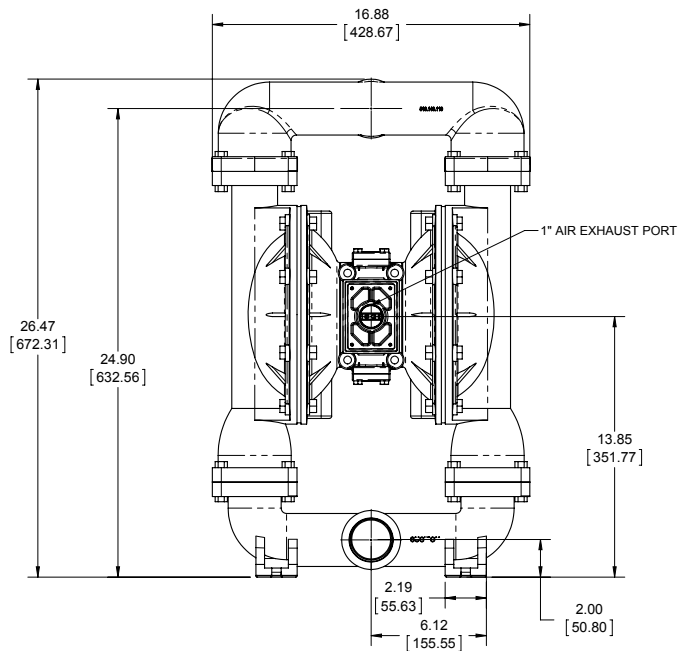

BOTTOM VIEW

# Dimensional Drawings

## G20 Metallic - ANSI Flange

Dimensions in inches (mm dimensions in brackets). Dimensional Tolerance:  $\pm 1/8"$  ( $\pm 3\text{mm}$ )

The dimensions on this drawing are for reference only. A certified drawing can be requested if physical dimensions are needed.

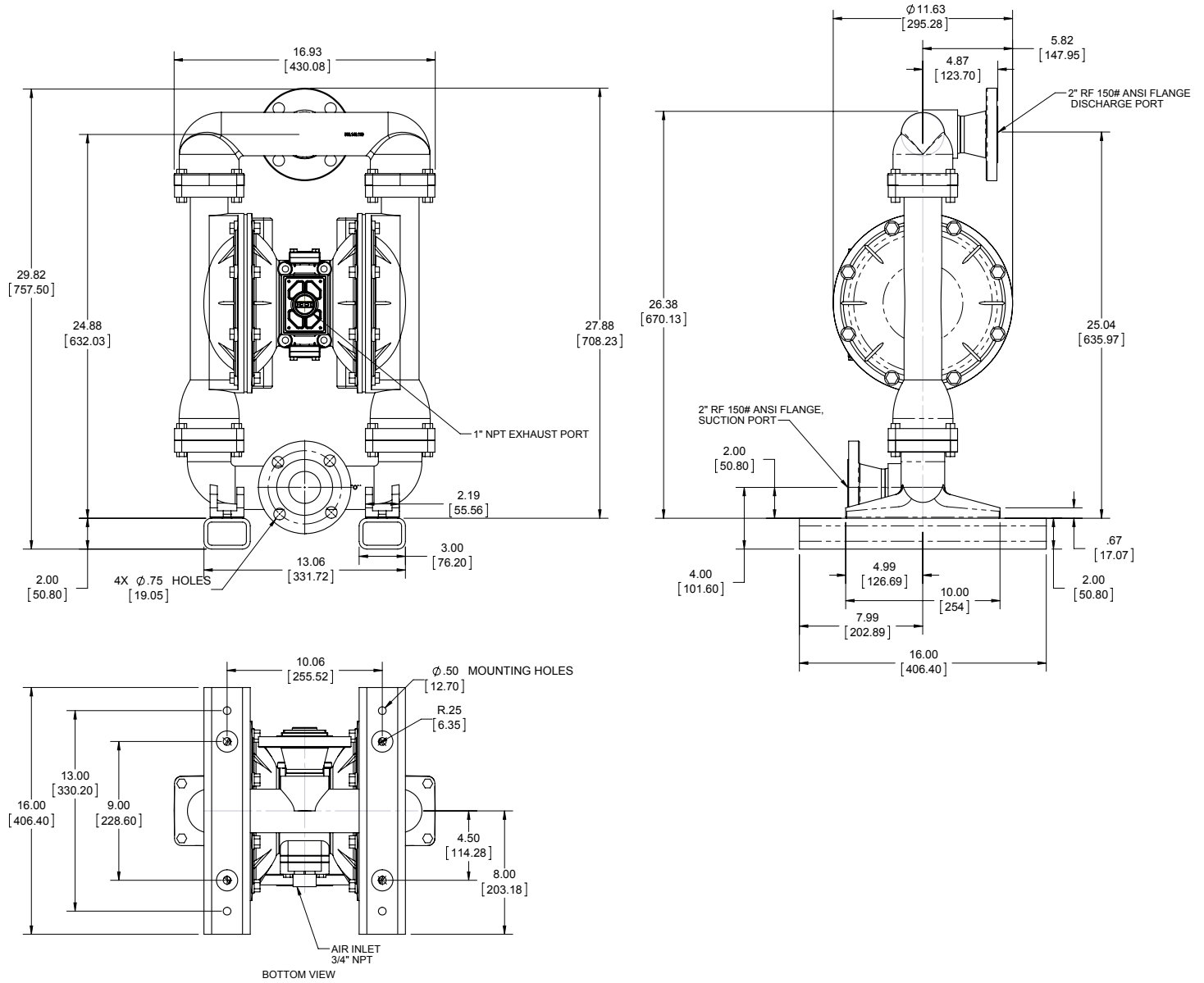

# Written Warranty

## 5 - YEAR Limited Product Warranty

Quality System ISO9001 Certified • Environmental Management Systems ISO14001 Certified

Warren Rupp, Inc. ("Warren Rupp") warrants to the original end-use purchaser that no product sold by Warren Rupp that bears a Warren Rupp brand shall fail under normal use and service due to a defect in material or workmanship within five years from the date of shipment from Warren Rupp's factory. Warren Rupp brands include SANDPIPER®, MARATHON®, PortaPump®, SludgeMaster™ and Tranquilizer®.

~ See complete warranty at [www.sandpiperpump.com/About/guaranteesandwarranties.html](http://www.sandpiperpump.com/About/guaranteesandwarranties.html) ~

**WARREN  
RUPP, INC.®**

### Declaration of Conformity

**Manufacturer: Warren Rupp, Inc.®, 800 N. Main Street, P.O. Box 1568,  
Mansfield, Ohio, 44901-1568 USA**

Certifies that Air-Operated Double Diaphragm Pump Series: HDB, HDF, M Non-Metallic, S Non-Metallic, M Metallic, S Metallic, T Series, G Series, U Series, EH and SH High Pressure, RS Series, W Series, SMA and SPA Submersibles, and Tranquilizer Surge Suppressors comply with the European Community Directive 2006/42/EC on Machinery, according to Annex VIII. This product has used Harmonized Standard EN809:1998+A1:2009, Pumps and Pump Units for Liquids - Common Safety Requirements, to verify conformance.

David Roseberry  
Signature of authorized person

David Roseberry  
Printed name of authorized person

Revision Level: F

October 20, 2005  
Date of issue

Engineering Manager  
Title

August 23, 2012  
Date of revision

**IDEX**  
CORPORATION





# WARREN RUPP, INC.<sup>®</sup>

## EC Declaration of Conformity

In accordance with ATEX Directive 94/9/EC,  
Equipment intended for use in potentially explosive environments.

**Manufacturer: Warren Rupp, Inc.<sup>®</sup>, A Unit of IDEX Corporation**  
800 North Main Street, P.O. Box 1568, Mansfield, OH 44901-1568 USA

### EN 60079-25: 2004

For pumps equipped with Pulse Output ATEX Option  
KEMA Quality B.V. (0344)

**Applicable Standard:**  
EN13463-1: 2001,  
EN13463-5: 2003



### AODD Pumps and Surge Suppressors

For Type Examination Designations

### AODD (Air-Operated Double Diaphragm) Pumps

EC Type Examination Certificate No. Pumps: KEMA 09ATEX0071 X  
KEMA Quality B.V.  
Utrechtseweg 310  
6812 AR Arnhem, The Netherlands



**Tranquilizer<sup>®</sup>**



DATE/APPROVAL/TITLE:  
27 MAY 2010

*David Roseberry*  
David Roseberry, Engineering Manager

## ATEX Summary of Markings

| Type   | Marking  | Listed In   | Non-Conductive Fluids   |                               |
|--|--|---|---|-------------------------------|
| Pump types, S1F, S15, S20, and S30 provided with the pulse output option   | II 2 G Ex ia c IIC T5<br>II 3/2 G Ex ia c IIC T5<br>II 2 D Ex c iaD 20 IP67 T100°C | KEMA 09ATEX0071 X<br>CE 0344                      | KEMA 09ATEX0071 X<br>KEMA 09ATEX0071 X<br>KEMA 09ATEX0071 X   | No<br>Yes<br>Yes              |
| Pump types, S1F, S15, S20, and S30 provided with the integral solenoid option  | II 2 G EEx m c II T5<br>II 3/2 G EEx m c II T5<br>II 2 D c IP65 T100°C             | KEMA 09ATEX0071 X<br>CE 0344                      | KEMA 09ATEX0071 X<br>KEMA 09ATEX0071 X<br>KEMA 09ATEX0071 X   | No<br>Yes<br>Yes              |
| Pump types, HDB1½, HDB40, HDB2, HDB50, HDB3, HDF1, HDF25, HDF2, HDF3M, PB¼, S05, S1F, S15, S20, S30, SB1, SB25, ST1½, ST40, G15, G20, and G30, without the above listed options, no aluminum parts | II 1 G c T5<br>II 3/1 G c T5<br>II 1 D c T100°C<br>I M1 c<br>I M2 c                | KEMA 09ATEX0071 X<br>KEMA 09ATEX0072 X<br>CE 0344 | KEMA 09ATEX0071 X<br>KEMA 09ATEX0071 X<br>KEMA 09ATEX0071 X<br>KEMA 09ATEX0071 X<br>KEMA 09ATEX0072 X | No<br>Yes<br>Yes<br>No<br>Yes |
| Pump types, DMF2, DMF3, HDB1½, HDB40, HDB2, HDB50, HDB3, HDF1, HDF25, HDF2, HDF3M, PB¼, S05, S1F, S15, S20, S30, SB1, SB25, SE½, ST1, ST25, ST1½, ST40, U1F, G05, G1F, G15, G20, and G30           | II 2 G c T5<br>II 3/2 G c T5<br>II 2 D c T100°C                                    | KEMA 09ATEX0072 X<br>CE                           | KEMA 09ATEX0072 X<br>KEMA 09ATEX0072 X<br>KEMA 09ATEX0072 X   | No<br>Yes<br>Yes              |
| Surge Suppressors all types  | II 2 G T5<br>II 3/2 G T5<br>II 2 D T100°C  | KEMA 09ATEX0073<br>CE                             | KEMA 09ATEX0073<br>KEMA 09ATEX0073<br>KEMA 09ATEX0073   | No<br>Yes<br>Yes              |

EC Type Certificate No. Pumps: KEMA 09ATEX0071 X  
Type Certificate No. Pumps: KEMA 09ATEX0072 X  
Type Certificate No. Suppressors: KEMA 09ATEX0073